

OCTAVE

HP 500 SE

INTRODUCTION

Congratulations and thank you for choosing the OCTAVE

HP 500 SE

limited edition

You are about to enjoy the benefits of one of the world's most innovative and reliable amplifiers. Take care of it, and your amplifier will provide you with many years of listening pleasure.

You often hear people claim that there has been no real progress in tube amplifier design for years. The operating principles of tubes have been documented extensively and are well known to amplifier designers. The same can, of course, be said for transistor amplifiers.

Nevertheless, there is still room for further development with both of these technologies. This is both necessary and desirable. With tube amplifiers in particular, a general reluctance to depart from the classic circuit designs has not done the technology any favours. Today's loudspeakers and source equipment provide better performance than ever before, but also make greater demands on amplifiers. Modern sound reproduction equipment delivers a level of performance at a price that simply would not have been possible 20 or even 10 years ago.

These advances have been achieved through the application of cutting edge technology as it becomes available and affordable.

Integrating these technologies into amplifier design demands a detailed knowledge of the inner workings of amplifiers and an appreciation of the sonic ramifications of each modification.

We have specialized in tube amplification for the past 20 years, during which time we have developed a number of innovative technologies that have earned us a reputation as one of the leaders in the field.

We hope you will enjoy many hours of wonderful music with your OCTAVE amplifier.



Andreas Hofmann

OWNER'S CERTIFICATE



The exclusive Octave HP 500 Mk III Jubilee Edition has been revised and refined in numerous ways in response to suggestions made by the editorial team at Stereoplay magazine. This version was approved by the editorial team following exhaustive listening tests. The sonic performance of each of the 99 Limited Edition units far exceeds that of the standard models.

We trust that this product will provide you with many years of listening pleasure.

CONTENTS

	Page
Introduction	
Owner's Certificate	
1. OCTAVE technology	7
1.1. Differences to other tube amps	7
1.2. Description.....	8
2. Safety instructions	9
2.1. Before you begin	9
2.2. Placement.....	10
2.3. Warranty	10
3. Setting up	11
3.1. Connecting the amplifier.....	11
3.2. Running in	11
4. Operation: Front panel	12
5. Connections: Rear panel	14
6. The outboard power supply	15
6.1. Description.....	15
6.2. Rear panel for 230/115 V grounded mains	16
6.3. Rear panel for 100 V ungrounded mains	17
7. Programmable remote control.....	18
8. Tubes	
8.1. Tube layout	19
8.2. Removing the grille.....	20
8.3. Replacing tubes.....	21
8.4. Tube service life	21
9. Option: Phono MM/MC	22
9.1. Description.....	22
9.2. Adjusting the MC input	23
10. Troubleshooting.....	24
11. Technical data and dimensions.....	25
12. Specifications	27

1. OCTAVE TECHNOLOGY

1.1. OCTAVE amps in contrast to other tube amplifiers

- Sound**
 1. The design goal of OCTAVE amplifiers is honest, natural sound reproduction. The sound characteristics of an amplifier are derived from the sum of all its parts. Tubes do not themselves guarantee high quality sound.
- Amplifier Design**
 2. The limitations of classic tube designs are evident as soon as you connect the speakers. These designs often only perform to their full potential when they are used with special loudspeakers. OCTAVE amplification and power supply technology has largely overcome these well-known problems. Thanks to their unique output stage design, they will maintain their optimum sound quality with virtually any loudspeaker, irrespective of its load.
- Control + Monitoring**
 3. OCTAVE employs the latest electronic circuit designs to create the best possible operating conditions for the tubes, and thus for the amplifier itself.

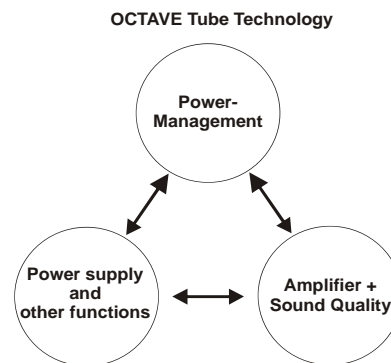

OCTAVE amplifiers are equipped with a proprietary control and monitoring system we call Power Management. This is an "electronic brain" within the amp that regulates and controls all of the amplifier's functions. It includes the **Soft Start Electronics** that gently ramp up the heating and supply voltages to save wear and tear on the components. In the event of a problem, the Power Management's **protection system** will disconnect the unit from the power supply. Power Management helps us to achieve a completely consistent sound while at the same time ensuring the total reliability of our products.

- Hand built**
 4. OCTAVE amplifiers are hand built and individually tested. They are designed and developed by Andreas Hofmann. The company has its own winding department, in which all transformers are specially custom wound for each amplifier.
- made in Germany**
 5. OCTAVE amplifiers are 100% built in Germany. Our employees are highly qualified and committed. We collaborate closely with local specialist subcontracting companies. The hardware components are all manufactured on modern CNC machines.

1. OCTAVE TECHNOLOGY

1.2. Description HP 500 SE

Negative feedback	The HP 500 SE Line is a two-stage tube amplifier with overall negative feedback. Amplifiers with feedback make ideal preamplifiers. Feedback reduces the sensitivity to manufacturing tolerances to a negligible level and also produces a low impedance output. Unless the output impedance of the line stage is kept to below 200 ohms, dynamics are compromised and fine detail is lost.
Tubes	In the HP 500 SE, an ECC 82 is responsible for the input section of both channels, with 2 x EF 184 (D 3A) wide-bandwidth pentodes in the output. The tubes operate in class A. Their extremely low impedance allows them to deliver a high output current.
Bandwidth	The SE version differs from the standard HP 500 in the way its output configuration has been dramatically overdimensioned. There are also major differences in the power supply. The output stage has been designed for maximum bandwidth with a view to extending the low frequency response downwards rather than extending the upper frequency limit. As a result, this amplifier reproduces bass instruments with great definition and authority - without a trace of bloom. The ability to reproduce fundamentals cleanly is a prerequisite for a natural midrange, and a high upper frequency bandwidth is important for consistently low distortion. The designer's intention is that the amplifier should not add any colouration of its own to the sound. The bandwidth of the line stage extends from 0.2 Hz - 2.3 MHz, +0 - 6 dB at low gain.
Stabilized power supply	The power supply has now been fitted with electronic stabilization throughout. A low noise floor is only possible when the supply current is absolutely clean. We therefore use MOSFET transistors to regulate the high-voltage supply. The heating and auxiliary circuits are also stabilized. All voltages have a noise and hum component less than 300 μ V. The benefit of all these measures can be seen in the signal-to-noise ratio of the line stage, which demonstrates an unusually high value of -103 dB
Power Management	Preamplifier stabilization is integrated with the electronic soft start surge control (Power Management). Soft start, which carefully ramps up the heating and supply voltages, is extremely important in extending the life of the tubes and maintaining a consistent sound from the tubes. It also relieves the power supply components of the strain of handling huge surge currents at turn-on and assists the tubes in achieving a service life as long as 10 years.
Gain switch	You can adjust the gain of the line stage in the HP 500 SE. This means you can tailor the effective adjustment range of the volume control to suit your particular power amp-loudspeaker system.
True symmetry	Also new is the transformer-coupled XLR output. The only way to achieve true, fully floating balanced signals is with a transformer. Balanced inputs depends on the + and - signals being exactly 180 degrees apart. This is where audio transformers come into their own because transformer coupling can provide two perfectly out-of-phase signals from the very lowest frequencies up - without introducing any group delay distortion. Another advantage of transformers is that they provide galvanic isolation, which makes it impossible for earth loops to develop between the preamplifier and power amplifiers or active loudspeakers.
Switchable phono	Phono input The HP 500 SE can be supplied with an optional phono preamp, providing separate inputs for MM and MC. The input impedance for MC is adjustable between 37 and 500 ohms.

2. SAFETY INSTRUCTIONS

2.1. Before you begin

Before using your HP 500 SE, please check your local line voltage and pay attention to this manual

In case of emergency: disconnect the plug from the mains supply

Never use an amplifier that is damaged or faulty. Make sure that it cannot be used until it has been repaired by a qualified service engineer.

Make sure that there is easy access to the IEC socket and power cord.

Do not open the case

There are dangerously high voltages and hot tubes inside this equipment. To avoid a burn or the risk of electric shock, never allow anyone except qualified personnel to open the case or remove the grille.

Servicing and maintenance

For reasons of safety, please ensure that servicing, repairs and other modifications to OCTAVE equipment are carried out only by a qualified technician. Fuses should also only be changed by a qualified technician. Always replace fuses with ones of the same type and rating. If your amplifier requires servicing, please ship or take your equipment directly to OCTAVE or to one of our authorized service centres.

Explanation of the warning symbols:



The exclamation point within an equilateral triangle is intended to alert the user to important operating and maintenance instructions.



The lightning flash with arrowhead symbol within an equilateral triangle is intended to alert the user to the presence of uninsulated 'dangerous voltages' within the product's enclosure that may be sufficient to constitute a risk of electric shock to persons.

Before connecting

Make sure that the voltage of your amplifier matches your electricity supply voltage.

Grounding

This amplifier is a protection class 2 device (without an earth conductor).

2. SAFETY INSTRUCTIONS

2.2. Placement

1. Location

OCTAVE equipment is designed strictly for use in a dry domestic environment. Do not use it in the open air or in damp environments!

Never place plants or liquid filled containers on your OCTAVE equipment. Take care that objects do not fall or liquids are not spilled into the enclosure. Should this happen, remove the mains plug immediately and have your amplifier checked by a qualified service technician.

Condensation may form if the amplifier is taken from a cold environment into a warm one. If you do this, wait until the amplifier has reached room temperature and is dry before switching it on.

Avoid installing the unit close to sources of heat such as radiators or anywhere that it may be in direct sunlight.

Do not operate the unit near flammable materials, gases or vapours. Avoid areas where there may be heavy accumulations of dust or where the unit may be subject to mechanical vibration.

Place your OCTAVE amplifier on a stable, even surface.

2. Cover

Never operate the amplifier without the cover.

3. Ventilation

Make sure that your amplifier has a good flow of air around it. If you intend to install your equipment in a cupboard or a shelf unit, ensure that there is at least a ten centimetre gap between the ventilation slots and the walls all around the amplifier. Do not rest the equipment on a soft surface such as carpet or foam sheeting.

2.3. Warranty

OCTAVE can only guarantee the safety, reliability and performance of this unit if modifications and repairs are carried out by specialized personnel and if the amplifier is operated in accordance with the instructions contained in this manual.

3. SETTING UP

3.1. Connecting the amplifier

1. In your own interest, please observe the safety precautions and positioning advice (Chapter 2)
2. Before connecting your OCTAVE amplifier up, switch off all the other equipment that you intend to connect to it. This will avoid a source of possible problems when you plug these components in.
3. Connect the inputs from your amplifier to the appropriate outputs on the HP 500 SE amplifier.
4. Connect your loudspeakers to your power amplifier, making sure that you observe the correct polarity (positive on the amplifier to positive on the speakers).
5. Check that the amplifier is switched off before connecting the power cable to the wall socket.
6. The stand by/power rotary switch for the HP 500 SE is located on the front panel (see Chapter 4, Operation)
7. Check that the volume control is not set at maximum before playing music through the amplifier.
8. Switch on the mains power, the push-button-switch is located on the rear panel of the power supply.

***The preamplifier needs approx. 4 minutes warm up time. In the warm up time the output is shorted to ground to avoid disturbances.
When switching the mode switch from normal to - 6 dB gain operation, the output is muted for approx 2 minutes.
If you switch from high to low or vice versa the muting time will start again***
9. Switch on the other components.

3.2. Running in

All OCTAVE equipment is subject to a 48-hour soak test at the factory to burn in the tubes. The tubes are preselected for use in each particular model.

The sound quality of tube equipment improves throughout the initial running-in period of up to three months.

During this time, daily use is beneficial (even at high levels) but not a requirement. Continuous operation does very little to help reduce the running-in time and is therefore not recommended.

4. OPERATION - Front panel

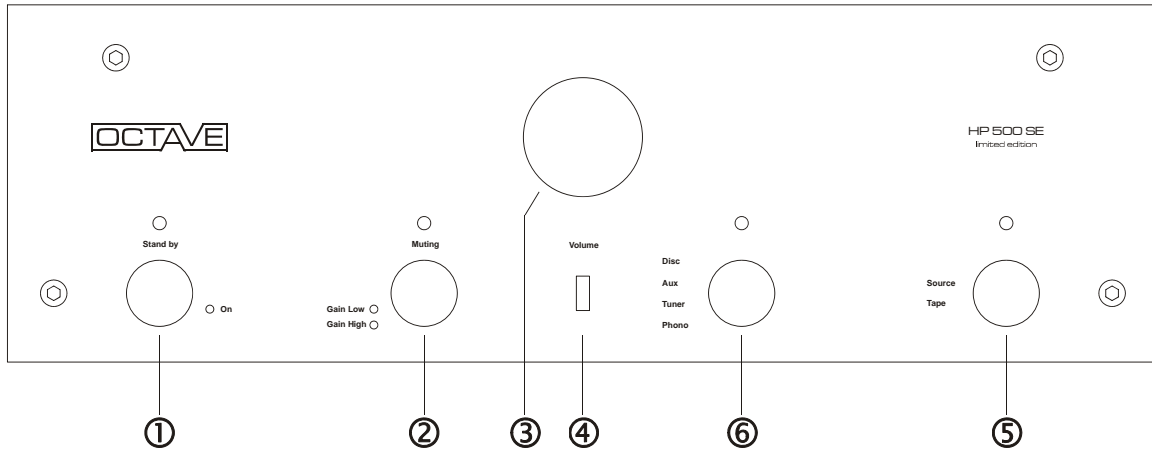

① Power (standby switch)

The LED above the switch illuminates when the power is on. When it is switched off here, the amplifier remains in standby mode with certain sections of the amplifier still operational. When the preamplifier is switched on, the ON LED will also illuminate. If you do not intend to use the preamplifier for a while, switch the unit off using the on/off switch on the outboard power supply.

② Muting gain switch

This rotary switch has two functions and three positions. First, it changes the gain of the line stage. The setting is shown by the "low" and "high" LEDs. You can also use this switch to activate the muting function. The LED above the switch illuminates when the muting is on.

The muting function short-circuits the preamplifier outputs. Use the muting feature whenever you plug or unplug cables to or from the preamplifier, as it isolates the preamplifier outputs from the power amp, allowing you to swap cables without switching the preamplifier off.

When using the muting function, you should also turn the volume control to zero.

Use the low/high gain setting to adjust the preamp output to suit the efficiency of your loudspeakers and increase the sensitivity of the volume control.

When you change the position of the switch, the muting function automatically activates to avoid sending switching noises to your speakers.

4. OPERATION - Front panel

③ Volume control

④ IR sensor

The infrared receiver is located below the volume control. Make sure that this area is not covered.

⑤ Tape/Source switch

Switch in **Source** position: The LED above the input selector ⑥ knob illuminates to show which source has been selected (Disc, Aux, Tuner or Phono).

Switch in **Tape** position: The LED above the Tape/Source switch ⑤ illuminates to show that tape playback has been selected. While your tape machine is recording, you can carry out off-tape monitoring, i.e. you can monitor the actual recording off-tape as you are making it. For more information on this facility, refer to the instruction manual for your cassette recorder, DAT, etc.

⑥ Input selector switch

When the LED above the input selector rotary switch illuminates (Tape/Source knob ⑤ switched to Source), your preamplifier will play your selected source:

Disc	CD playback
Aux	Input for an additional line level device.
Tuner	Radio or tuner playback
Phono	Line version: line level input for an external phono preamplifier.
	Phono version: playback of MM or MC (see rear panel diagram)

You can record the source you are listening to via a recorder connected to the REC output on the rear of the HP 500.

Please note:

The HP 500 SE is fitted with a switch-on delay. This increases the life of the tubes and suppresses switch-on noises, as the output of the preamplifier is muted during the switch-on process. At the end of the 4-minute delay, the output is enabled and the LED above the Tape or Input Selector switch will illuminate, depending upon the position of the Tape/Source knob.

5. CONNECTIONS: Rear panel

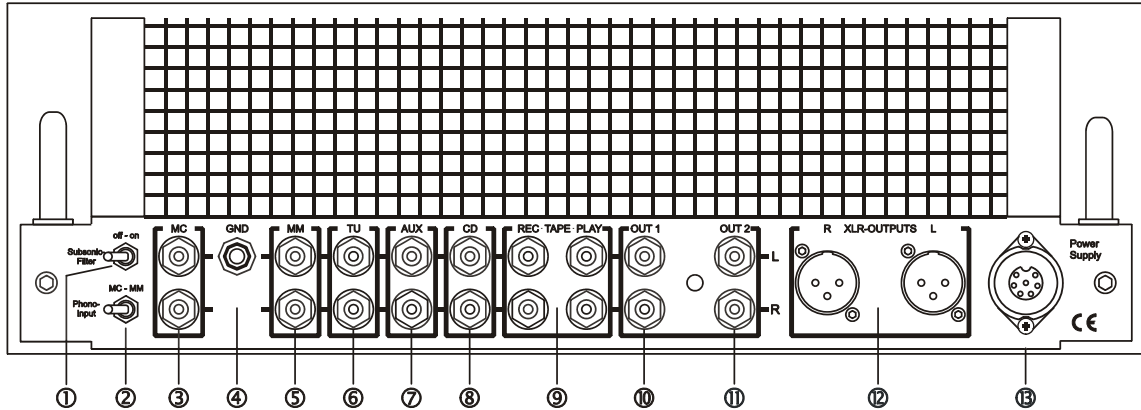

- | | | |
|---|-------------------------------|--|
| ① | Subsonic filter | Left position - off, right position - on |
| ② | Phono selector switch | (MM/MC version only)
The toggle switch selects the MM or MC input |
| ③ | MC input | Input for moving coil pickup |
| ④ | GND | Ground (earth) connection
For connecting an earthing wire to the turntable (if required). See also the section "Connecting to your stereo system" |
| ⑤ | MM input | Input for moving magnet pickup |
| ⑥ | Tuner input | |
| ⑦ | AUX input | Input for video, TV, etc. |
| ⑧ | CD input | |
| ⑨ | Tape rec
Tape play | Output to tape machine
Input from tape machine |
| ⑩ | OUT 1 + 2 | RCA phono outputs to the power amplifiers |
| ⑪ | XLR output | For balanced power amplifiers |
| ⑫ | Power connector | for the outboard power supply |

Comment: In the connection area, the lower socket line (red) is for the right channel, the upper socket line (white) is for the left channel.
Pin configuration XLR-sockets: : 1 = ground, 2 = plus, 3 = minus

6. OUTBOARD POWER SUPPLY

6.1. Description

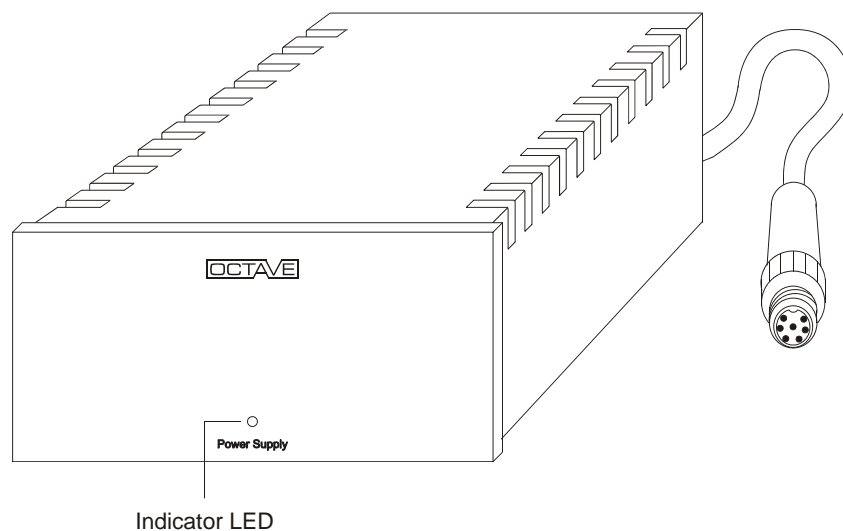

The LED illuminates when the unit is switched on.

The HP 500 SE is equipped with a specially designed external power supply incorporating highly effective mains and high frequency filters. To provide maximum shielding from electromagnetic interference, the unit is housed in a separate case. The transformer has been specially designed for the HP 500 SE. It cannot be used with any other device.

Benefits

The Power Supply contributes substantially to the improved sound quality of the HP 500 SE. Its design is based on the realization that an effective improvement in sound quality can be achieved by completely isolating the preamplifier from the mains (simulated battery powered operation). Classic LC filters can reduce high frequency interference but cannot reduce low frequency interference or ground currents that are part and parcel of a "normal" power supply. Ground currents are interference currents in the signal cables connecting the various components in a stereo system. They have a definite negative effect on sound quality.

We developed a special isolation transformer that also demonstrates very good high frequency filtering characteristics. We have been able to eliminate these ground currents by completely isolating the components from the mains.

6. OUTBOARD POWER SUPPLY

6.2. Rear panel for 230/115 V grounded mains

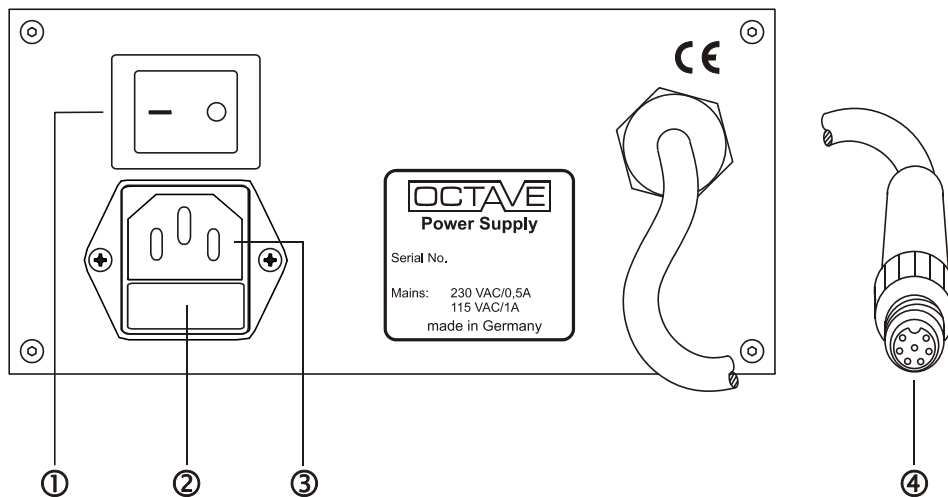

① **On/off switch**

Switch the unit off using this switch if you do not intend to use the preamplifier for some time.

② **AC input**

three-pin IEC receptacle:
A power cable is supplied with your preamplifier.

③ **Fuse holder**

230 V mains: 0.63 A time-lag fuse.
115 V mains: 1 A time-lag fuse.
Fuse type: EN 60127-2/5
Changing the fuse should be left to a qualified service technician!

④ **Preamplifier connecting cable (120 cm)**

Plugging in. When plugging in the connector, observe the anti-rotation lug and take care not to overtighten the coupling ring!

6. OUTBOARD POWER SUPPLY

6.3. Rear panel for 100 V mains (ungrounded)

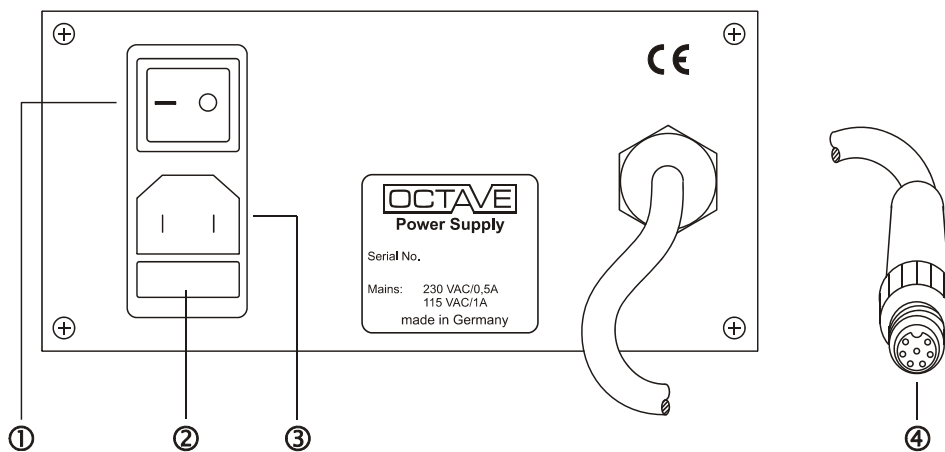

① **On/off switch**

Switch the unit off using this switch if you do not intend to use the preamplifier for some time.

② **Fuse holder**

100 V mains: 1,6 A time-lag fuse.
 Fuse type: EN 60127-2/5
 Changing the fuse should be left to a qualified service technician!

③ **AC input**

two-pin IEC receptacle:
 A power cable is supplied with your preamplifier.

④ **Preamplifier connecting cable (120 cm)**

Plugging in. When plugging in the connector, observe the anti-rotation lug and take care not to overtighten the coupling ring!

7. PROGRAMMABLE REMOTE CONTROL

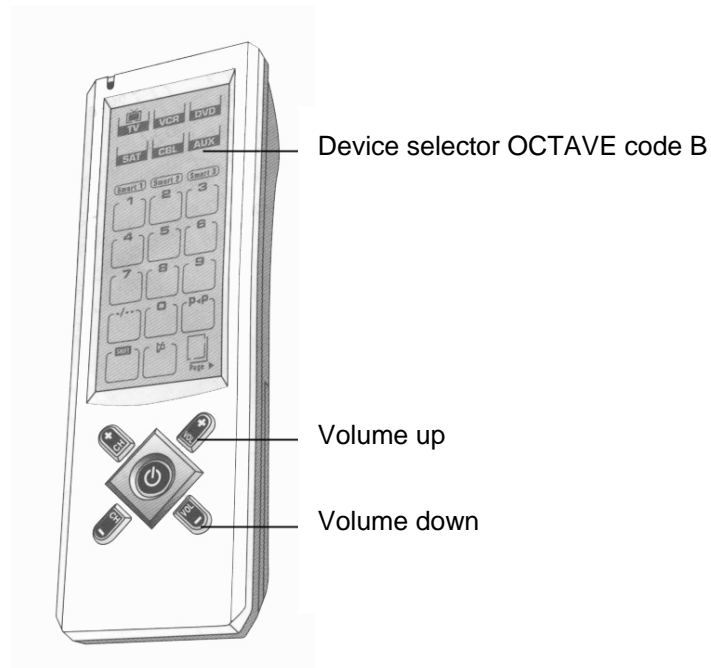

Select your OCTAVE amplifier on the touch screen panel with button AUX.
Once selected you can always control the volume directly by pushing the button Vol + or Vol - .
Detailed information relating the use of the remote control you find in the owner's manual of the HOME THEATRE MASTER REMOTE

8. TUBES

8.1. Tube layout

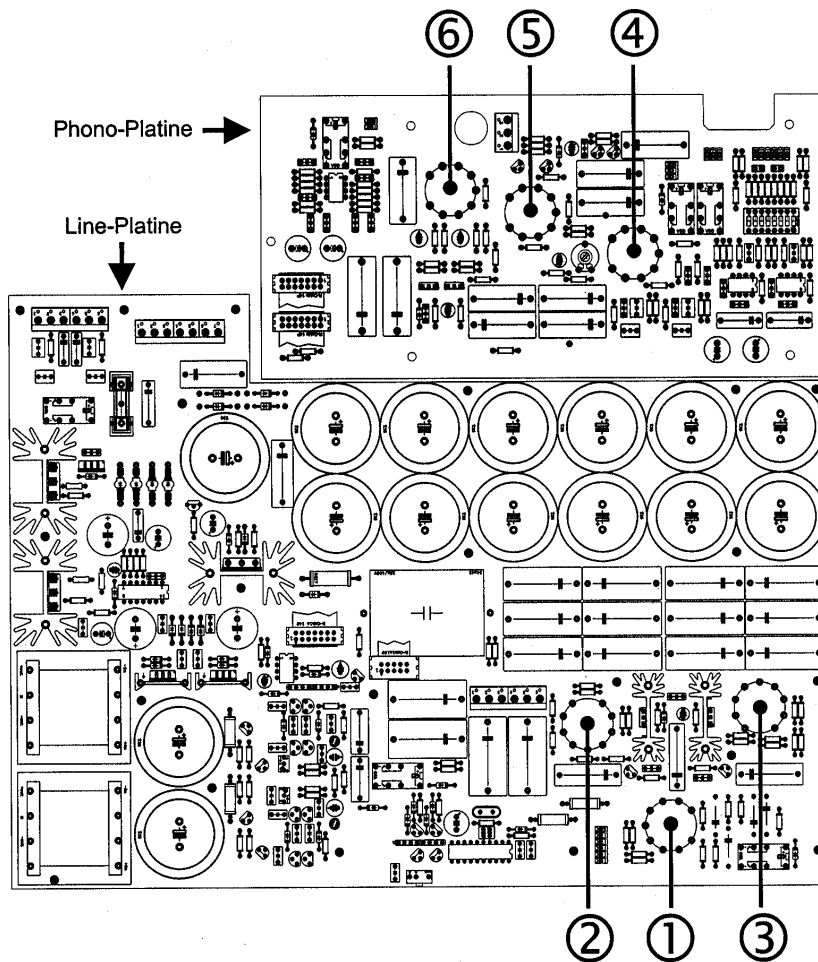

Before opening the cover it is mandatory to remove the power cord from the mains power inlet.

Line board:	①	ECC 82 / 12 AU 7
	② + ③	EF 184
Phono board:	④	ECC 83 / 12 AX 7
	⑤	ECC 81 / 12 AT 7
	⑥	ECC 88 / 6922

8. TUBES

8.2. Removing the grille

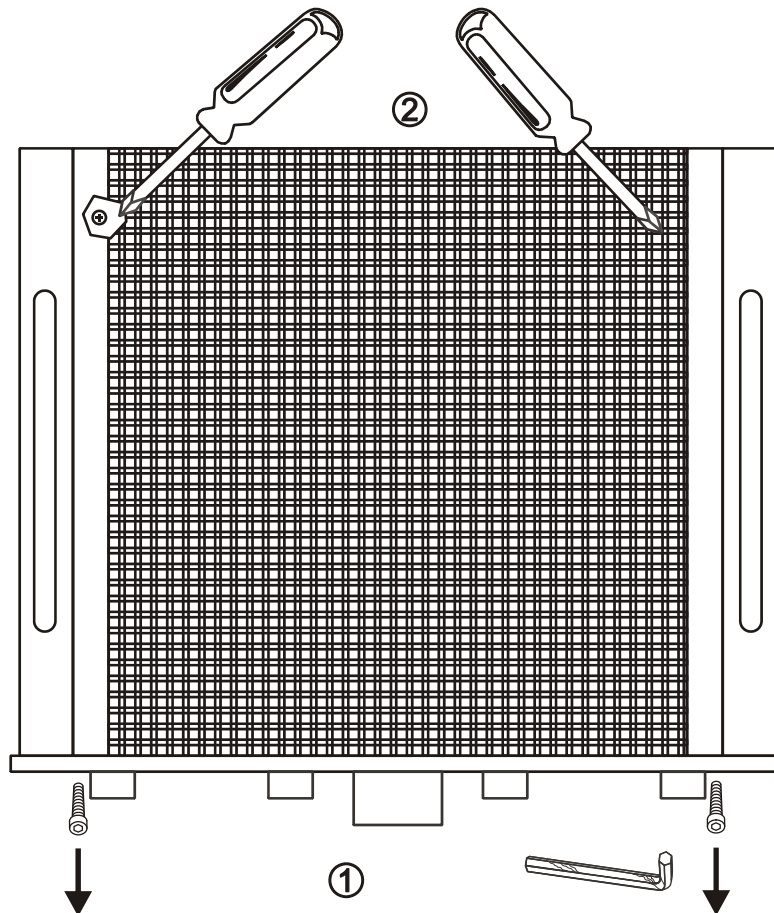

First, switch the unit off and remove the mains plug from its wall socket.

1. Remove the two Allen bolts located at the top left and right of the front panel using a size 4 Allen key.
2. Insert a Philips no. 1 screwdriver through the grille at the rear of the unit, and undo the two Philips screws at the left and right. These screws have retainers to prevent them being removed completely. You will need a screwdriver with a shaft that is long enough to reach through the grille.
3. Lift up the cover.

8. TUBES

8.3. Replacing tubes

Please use only original OCTAVE replacement tubes. These have been selected and tested for use in our amplifiers. ***Important! Changing tubes is a job for a qualified technician!***

1. Switch off the preamplifier, unplug the power cord from the wall socket, and allow the unit 10 minutes to cool down.
2. Please refer to the drawing **8.2. Removing the cover**
3. Take out the old tubes.
Carefully remove the tubes from their sockets, taking care not to exert sideward pressure on the sockets.
4. Fit new tubes
Please ensure that the tube pins are all perfectly straight before inserting your new tubes. Straighten any bent pins very carefully by hand if necessary.
5. Cleaning tips
Cleaning agents and contact cleaners are not recommended for tube sockets. Clean dirty sockets with compressed air and carefully clean tarnished tube pins using a wire brush.
6. Please note:
No adjustments are necessary to your amplifier after fitting new tubes.
It may take new tubes some time (up to 300 hours) to achieve their optimum sound quality.
Manufacturing faults in tubes may only become evident after about 100 hours of use. You should therefore be wary of installing untested tubes. However, faulty tubes or tubes of the incorrect type will normally not damage the amplifier.

8.4. Tube service life

- Thanks to the protection circuits and soft start electronics, the output tubes used in your amplifier should achieve an average service life of 10 years.
- Because the tubes have different service lives, it should never be necessary to renew the entire tube complement at the same time.

9. PHONO MM/MC OPTION

9.1. Description

The role of the phono preamplifier

A record player is an electro-mechanical device. Music signals are "pressed" into the grooves in the record, and these are physically tracked and read by the pickup cartridge. In order to get the entire 20 Hz - 20 KHz frequency range into the grooves, the frequency response has to be shaped by lowering the level of the low frequency information and raising the level of the high frequency information. This predefined equalization curve is known as RIAA equalization.

A phono amplifier must exactly equalize for RIAA recording characteristic if it is to avoid colouring the sound. Equalization accuracy must be within 0.5 dB over the entire frequency range, with channel matching of at least 0.1 dB.

The phono section of the HP 500 SE

The phono section of the HP 500 SE is an enhanced version of our hybrid phono technology. The phono section now offers a greater level of compatibility with low output and low impedance moving coil cartridges. Most preamps have problems with such cartridges, since both gain and input impedance issues have to be addressed simultaneously.

We have developed an MM/MC head amp that successfully eliminates the problem areas. At the heart of the equalizer is a tube circuit containing 3 tubes. It incorporates a switchable subsonic filter, which prevents very low frequencies generated by warped records or tonearm resonances from overloading the loudspeakers. ①

Guidelines for connecting to the phono section

- 1 Plug the RCA phono cable from your turntable into the appropriate (MC ③ or MM ⑤) input on your HP 500 SE. Turn the input selector ② to phono.
2. Connect the earth cable supplied with your turntable to the GND connection on the HP 500 SE ④, following the instructions provided by the turntable/arm manufacturer. Some tonearms do not have a separate earth cable, as the pickup system is earthed via the RCA phono plugs.

Explanation:

The earth is generally connected to the tonearm or the headshell. This is necessary to prevent hum or radio interference. It is usually advisable to connect the earth cable to reduce this kind of interference.

9. PHONO MM/MC OPTION

9.2. Adjusting the MC input

Before you can adjust the MC input, you need to remove the grille from your preamplifier (see "Removing the grille").

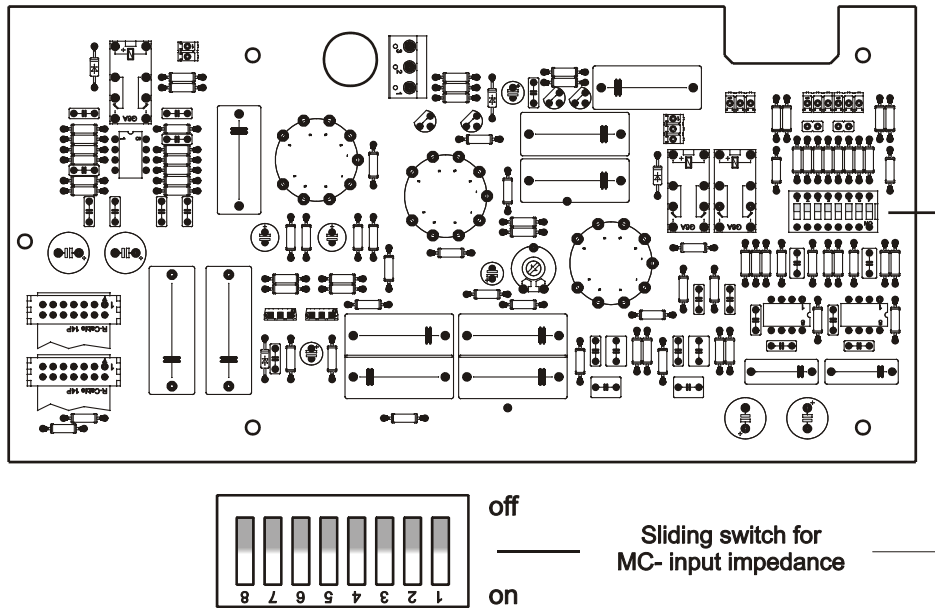

Slider switches for MC input impedance

Switch option	Left channel Switch 1 – 4			Right channel Switch 5 - 8		
	Switch no.	Switch position	Resistance (ohms)	Switch no.	Switch position	Resistance (ohms)
1	All	Off	500	All	Off	500
2	1	On	330	5	On	330
3	2	On	200	6	On	200
4	1 + 2	On	166	5 + 6	On	166
5	3	On	97	7	On	97
6	1 + 3	On	88	5 + 7	On	88
7	2 + 3	On	75	6 + 7	On	75
8	4	On	70	8	On	70
9	2 + 4	On	58	6 + 8	On	58
10	2 + 3 + 4	On	40	6 + 7 + 8	On	40
11	All	On	37	All	On	37

The input impedance setting is important in achieving a balanced sound from your pickup. You will find the recommended impedance in the specifications supplied with your pickup.
Default factory setting: 97 ohms

10. TROUBLESHOOTING

■ Hum and crackling

Hum in an audio system is often caused by several system components being earthed individually. It is particularly common with tuners, VCRs or satellite receivers, where the earthed aerial cables cause a hum loop via the aerial input. Power amplifiers are normally also earthed. Removing the earth wire on your mains plugs is not a solution. You can isolate the aerial earth connection with a special signal isolator. This device has no adverse affect on the sound or picture quality of tuners or TVs.

The HP 500 SE is not earthed (only the power supply is earthed) and cannot therefore cause ground loops.

■ Clicks and pops

Older fridges and 12 V halogen lamps can cause cracking through the loudspeakers when they switch on and off.

Solution: the only solution is to use a single power socket board for your entire system and to use a different power outlet in your listening room.

■ Channels are not balanced

Check that the phono plugs are a tight fit. Bend the outer earth contact inwards slightly if necessary. Sometimes the internal pin in a phono plug may not be a tight enough fit, in which case you should change either the interconnect or the socket.

1. Damaged cables and poorly fitting phono plugs can create resistance in the signal path, enough to reduce the output level of one channel.

Solution: Try new cables or clean plugs and sockets with isopropyl alcohol. You could also try cleaning or contact fluid.

2. A faulty tube can cause a drop in output in one channel and generate distortion. Although a rare occurrence, the heater inside the particular tube may be the cause of the problem.

Solution: Replace the tube.

■ Increased hiss on one channel

Hiss that varies in level is a sign of a faulty or worn driver tube.

Solution: Replace the worn tube.

11. TECHNICAL DATA AND DIMENSIONS

In- and Outputs

Inputs

6 x RCA (two of them are phono MM/MC with the option phono, without phono option the MM-input is line level, the MC-input is not mounted)
Bypass-Function for input Tape play is on request
2 x RCA, 1 x XLR, 1 x Tape Record (RCA)

Outputs

Line stage

Gain high	17.5 dB = 7.5
Gain low	9.5 dB = 3
Frequency response	3 Hz - 500 kHz 1.5 dB
Total harmonic distortion	0.001% at 3V / 7.5 kOhm
Signal-to-noise ratio: high gain	- 92 dB
Signal-to-noise ratio: low gain	- 103 dB
Channel separation	65 dB 1 kHz
Crosstalk rejection between inputs	- 86 dB 10 kHz
Input impedance	100 kOhm
Output impedance	100 ohms (RCA phono) 2 x 50 ohms XLR
Channel tracking of volume control	0.5 dB - 70 dB
Pin allocation, XLR output	Pin 1: ground Pin 2: + (hot) Pin 3: - (cold)

Phono MM

Input impedance	47 kOhm ° 130 pF
Sensitivity	3 mV
RIAA equalization accuracy	0.3 dB 15 Hz - 20 kHz
Gain	40 dB 1 kHz
Signal-to-noise ratio (weighted)	- 73 dB
Subsonic filter corner frequency	20 Hz / - 3 dB

Phono MC

Input impedance	37-500 ohms
Sensitivity	0.1 mV
Gain	30 dB
Signal-to-noise ratio (weighted)	- 75 dB

General:

Power consumption	50 VA
Weight, preamplifier	10 kg
Weight, power supply	4 kg
Dimensions, power supply (W x H x D)	18 x 10 x 28 cm
Standard accessories	power cable, remote control

11. TECHNICAL DATA AND DIMENSIONS

Overall dimensions of the preamplifier in mm

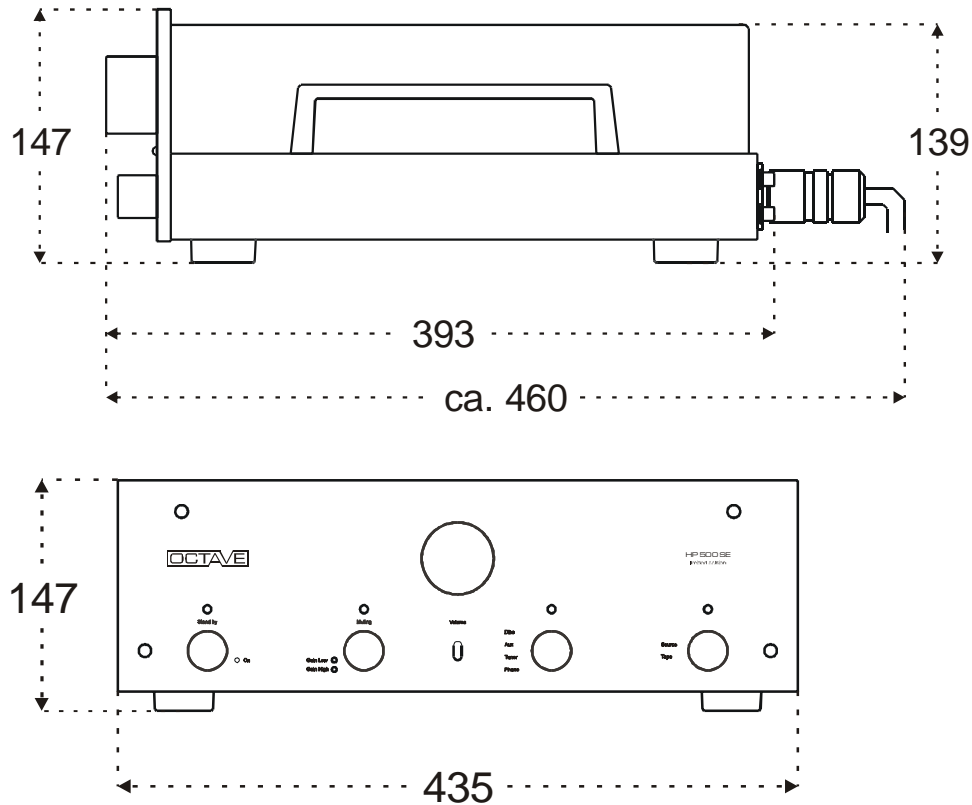

Features

- The HP 500 SE is fitted as standard with two RCA phono outputs and one XLR outputs.
- The XLR output is transformer-coupled and galvanically isolated.
- The HP 500 SE has separate inputs for MM/MC.
- An optional phono MM and MC module may be added any time.
- MC input impedance is adjustable over a wide range.
- Soft-start for heaters, operating voltage and signal output. This results in maximum service life of the tubes and noise-free switch-on/off. The output is enabled after 4 minutes.
- The line stage has two switchable gain settings
- Standby function to minimize power consumption and reduce startup time (for periods up to several hours).
- Outboard power supply with multiple screened mains transformer and built-in mains filter.

12. SPECIFICATION

Diagrams

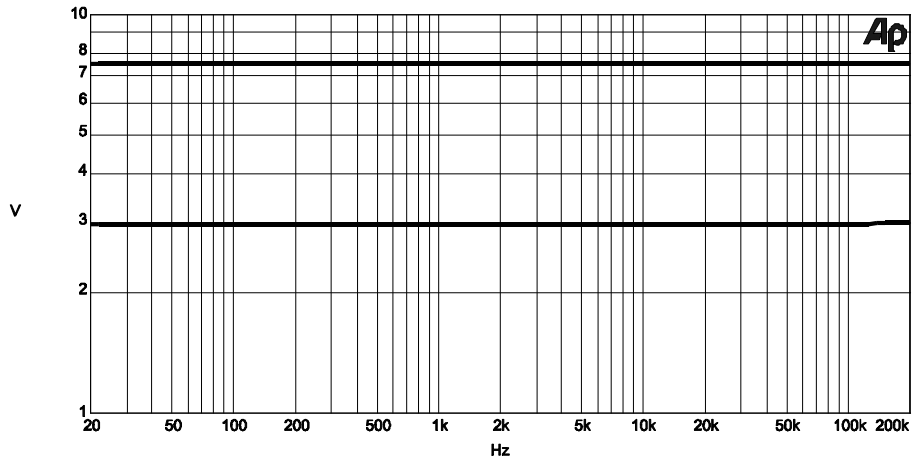

Frequency response accuracy of line stages in 'low gain' setting.
20 Hz - 200 kHz: 0.1 dB

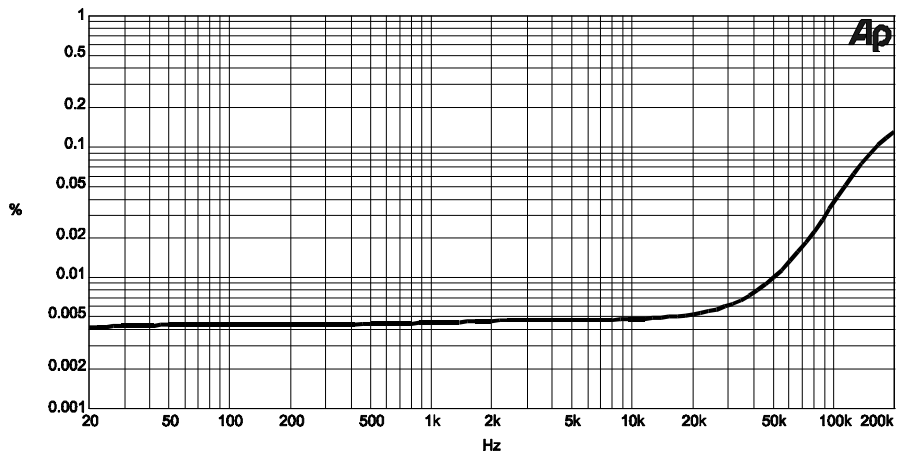

Overall distortion (THD + noise) of line stage from 20 Hz - 200 kHz.
Distortion remains low up to 20 kHz

12. SPECIFICATION

Diagrams

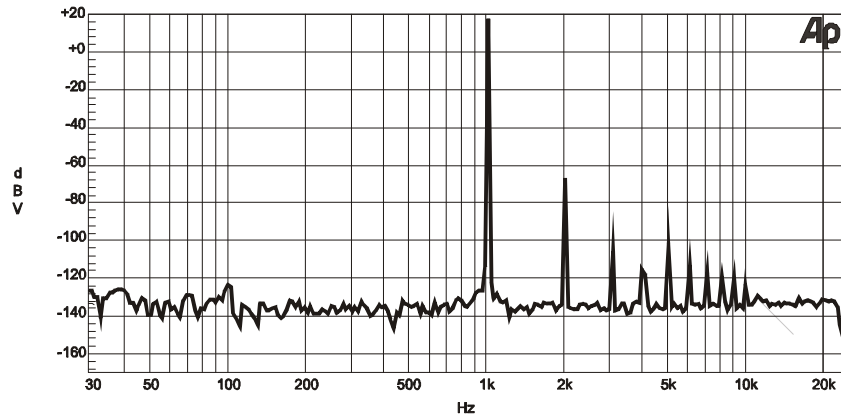

Noise spectrum of line stage, 4 V output at 1 kHz. The low level of harmonic distortion and low noise level are clearly visible. There are no hum components at 50 Hz and 100 Hz.

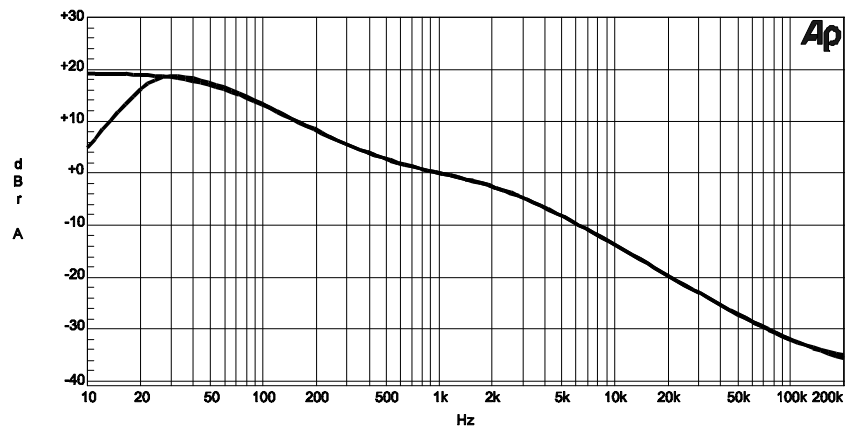

Frequency response of the phono stage with and without subsonic filter



We reserve the right to alter and improve the specifications in pursuit of better. OCTAVE logo is a registered trade mark of Andreas Hofmann. Copyright by Andreas Hofmann. Reproduction in whole or part is prohibited.
edited EN2010

OCTAVE AUDIO
Germany
www.octave.de